

HYDRAULIC BOLT TENSIONING

Drilled Hex Nuts

Hexagon nuts for use with subsea bolt tensioners require holes in the nut flats for tommy bar to rotate the nut through the tool window.

Hexagon nuts with drilled holes are available from Boltight. Boltight nuts have perpendicular machined bearing surfaces to give maximum bolt load retention and are PTFE coated.

METRIC HEAVY SERIES			
Bolt Dia	A1	B	C
mm	mm	mm	mm
M20	5	7	4*
M22	5	7	4*
M24	6	9	5*
M27	6	9	5*
M30	8	12	6*
M33	8	12	7*
M36	10	15	8*
M39	10	15	8
M42	10	15	9
M45	10	15	9
M48	12	18	11
M52	12	18	12
M56	14	21	12
M60	14	21	12
M64	16	24	14
M68	16	24	14
M72	16	24	14
M76	16	24	15
M80	16	30	15
M85	16	30	15
M90	16	30	18

IMPERIAL HEAVY SERIES			
Bolt Dia	A1	B	C
in	mm	mm	mm
3/4in	6	9	5.5
7/8in	6	9	6
1in	6	9	6.5
1-1/8in	6	9	7
1-1/4in	8	12	8
1-3/8in	8	12	8.5
1-1/2in	10	15	9
1-5/8in	10	15	9.5
1-3/4in	10	15	10.5
1-7/8in	10	15	11
2in	12	18	12
2-1/4in	12	18	13
2-1/2in	14	21	15
2-3/4in	14	21	16
3in	16	24	17
3-1/4in	16	24	18
3-1/2in	16	24	19

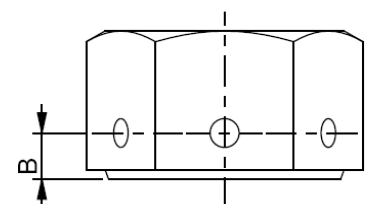
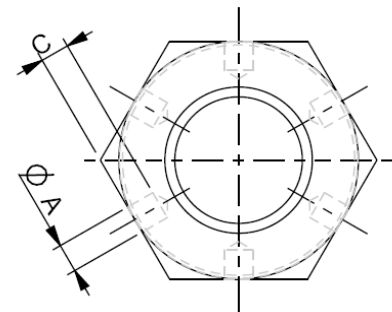

Notes

1 Tolerance +0.2/+0.1

* Flat Bottom



BOLTIGHT[®]
HYDRAULIC BOLT TENSIONING

BOLTIGHT is the UK
Registered Trade Mark
of Boltight Limited