

HYDRAULIC BOLT TENSIONING

Typhoon Tensioners Application Data

Help us assist you in specifying the correct Wind Turbine tool for your application. Please complete the below form as comprehensively as possible.



Company	
Tower Model	
Application:	
Blade	
Blade Bearing	
Tower Base	
Mid Flange	
Gearbox	
Hub Main Shaft	
Machine Base to Yaw Bearing	
Yaw Bearing to Tower	
Nacelle	
Foundation	
Other	
Bolt Specification	
Load Requirement	kN/klbf

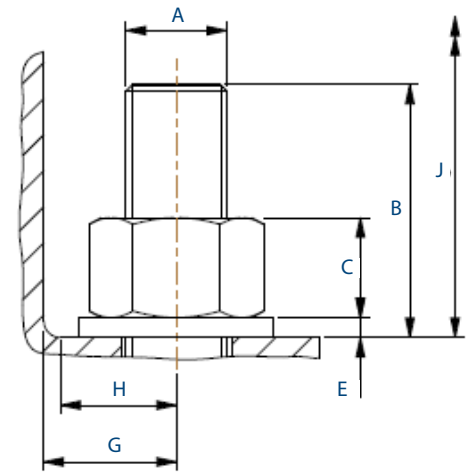

A - Bolt Size		mm
B - Stud Protrusion		mm
C - Nut Height		mm
D - Nut A/F		mm
E - Washer height		mm
F - Washer Diameter		mm
G - Radial Clearance		mm
H - Footprint Clearance		mm
J - Vertical Clearance (min)		mm
K - Pitch (min)		mm

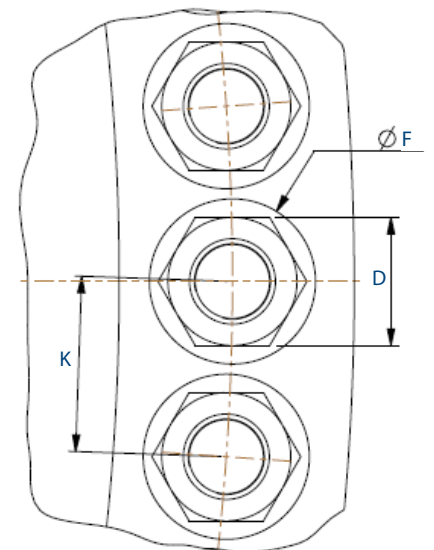

Comments	
----------	--

